



# CAPITAL PROJECT PUBLIC INFORMATION CENTRE

---

October 24 and 25, 2023



# INTRODUCTIONS

---



## PURPOSE AND OBJECTIVES

- Learn about the projects
- Understand the next steps
- Contact us

# Capital Projects



- Sidewalk Program
- Asphalt Program
- Culvert and Structure Replacement and Repairs
- Pedestrian Crossover
- Full Road Reconstruction

# Full Road Reconstruction - Design Considerations



- End of life sewers and watermains
- Overland drainage deficiencies
- Insufficient bury depth causing frost damage
- Insufficient road subgrade to support traffic
- Inconsistent cross section
- Required upgrades to support growth
- Correct improper service connections
- Traffic considerations



# Sidewalk



- Functionality Issues:
  - Sidewalk conductivity
  - Alignment and location
  - Width and condition
  - No sidewalk present

# Road Works - Benefits



- Improved traffic and pedestrian safety
- Better pedestrian connectivity and accessibility
- Improved road and boulevard drainage
- Urbanize roads throughout project area
- Improve intersection safety
- Improve maintenance operations and reduce cost of maintenance



# Storm Service



- Storm service installed to each property

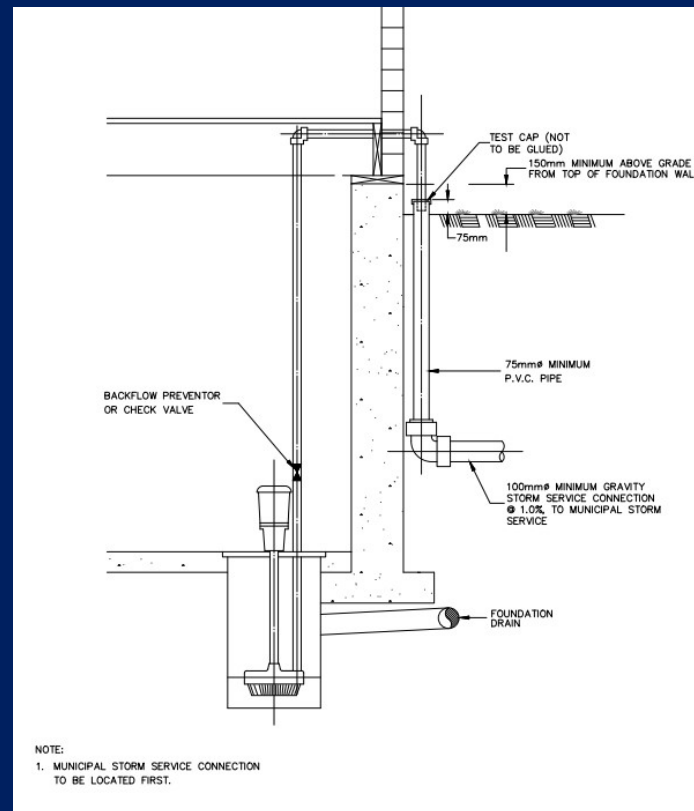

# Tree Impacts From Construction



- Location and grade of tree
- Infrastructure replacement to property line requires deep and wide trenches which inevitably removes and damages tree roots.
- Safety of construction workers
- Public safety to access clean drinking water and sewage outlet
- Accessible sidewalks

# Tree Re-Planting



- Offered to residents that are impacted by tree removal
- Tree species appropriate for urban environments

Scientific Name	Common Name
<i>Acer Nigrum</i>	Black Maple
<i>Acer Rubrum</i>	Red Maple
<i>Acer Saccharum</i>	Sugar Maple
<i>Aesculus Hippocastanum</i>	Common Horse Chestnut
<i>Phellodendron Amurense</i>	Amur Cork Tree
<i>Celtis Occidentalis</i>	Common Hackberry

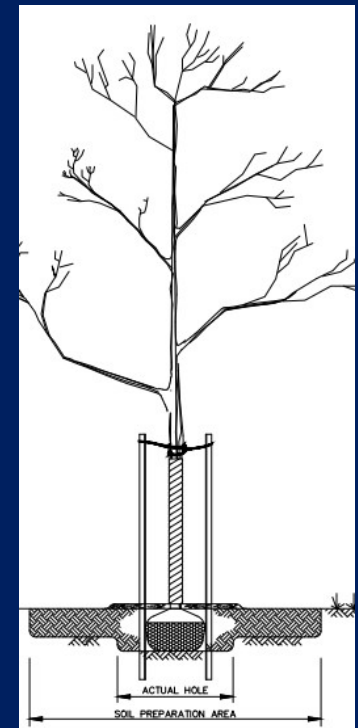

# Reconstruction - Completion



Pic 1  
Fergus Street South between Queen Street East and King Street East

# Public Feedback



- Feedback will be received until November 10, 2023.
- All comments will be reviewed and considered during the final design



# Project Updates



**Project updates can be viewed at**

**<https://www.wellington-north.com/government/capital-projects>**

# Project Contacts



## Township of Wellington North

Tammy Stevenson, C.E.T.  
Senior Project Manager  
Phone: (519) 848-3620, ext 4629  
tstevenson@wellington-north.com

## Consulting Engineers

Triton Engineering Services Limited  
Lindsay Scott, P.Eng.  
Project Manager  
Phone: (519) 843-3920  
lscott@tritoneng.on.ca

B.M. Ross and Associated Limited  
Izaak De Jager, P.Eng.  
Project Manager  
Phone: (519) 323-2945  
idejager@bmross.net

# Questions

